



# QDD10

## Electric Tractor 1.0t

Suitable for: Retailer /Wire container/ Platform Delivery  
Applicable Industry: Retail, Medical, Airport, Delivery and etc.

**EP EQUIPMENT CO.,LTD**  
[www.ep-equipment.com](http://www.ep-equipment.com)



# Electric tractor 1.0t

## QDD10

Distinguishing mark	1.1	Manufacturer			EP
	1.2	Model designation			QDD10
	1.3	Drive			Electric
	1.4	Operator type			Pedestrian
	1.5	Load capacity	Q	kg	1000
	1.9	Wheelbase	y	mm	315
Service weight	2.1	Service weight		kg	98
	2.2	Axle loading, laden front/rear		kg	98/0
	2.3	Axle loading, unladen front/rear		kg	78/20
Tyres/chassis	3.1	Tyre type			Pneumatic
	3.2	Tyre size, front		mm	2x $\Phi$ 250x85
	3.3	Tyre size, rear		mm	2x $\Phi$ 75x32
	3.4	Additional wheels (castor wheels)		mm	—
	3.5	Wheels, number front/rear (x=drive wheels)		mm	2x /2
	3.6	Tread width, front	b10	mm	428
	3.7	Tread width, rear	b11	mm	217
Dimensions	4.2.1	Overall height	h15	mm	890~976~1068
	4.8	Seat height/standing height	h7	mm	—
	4.9	Height of tiller handle in drive position min./max.	h14	mm	835~930~1010
	4.12	Tow coupling height	h10	mm	—
	4.19	Overall length	l1	mm	1255~1315~1345
	4.21	Overall width	b1/b2	mm	520
Performance data	4.32	Ground clearance, center of wheelbase	m2	mm	—
	5.1	Travel speed, laden/unladen		km/h	4.5/5
	5.5	Drawbar pull, laden/unladen		N	200/0
	5.6	Max. drawbar pull, laden/unladen		N	650/0
	5.8	Max. gradeability, laden/unladen		%	3/16
Electric-engine	5.10	Service brake			Electromagnetic
	6.1	Drive motor rating S2 60 min		kW	0.4
	6.4	Battery voltage/nominal capacity		V/Ah	2x12/50
	6.5	Battery weight		kg	2x19
Addition data	8.1	Type of drive control			DC
	10.5	Steering design			Mechanical
	10.7	Sound pressure level at the driver's ear		dB(A)	74
	10.8	Towing coupling, type DIN 15170			—

If there are improvements of technical parameters or configurations, no further notice will be given.  
The diagram shown may contain non-standard configurations.

## Solution Packages:

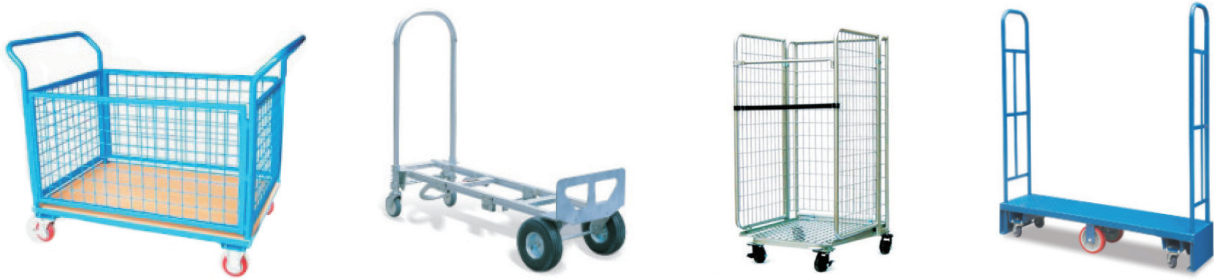

- Great Flexibility with Minimum Volume: Light Self-weight of 98KG only and the application of differential mechanism make it more flexible and easier to operate.
- Strong Traction: It can manage the towing task of 1000KG goods on a slope of 3% degrees.
- Stability in Operation and Excellent passingability: the application of pneumatic tyre with a diameter of 250mm.
- Easy to Charge: With the application of internal chargers, charging process can be realised where there is a socket.
- Comfortability in Operation: The height of the tiller is adjustable.

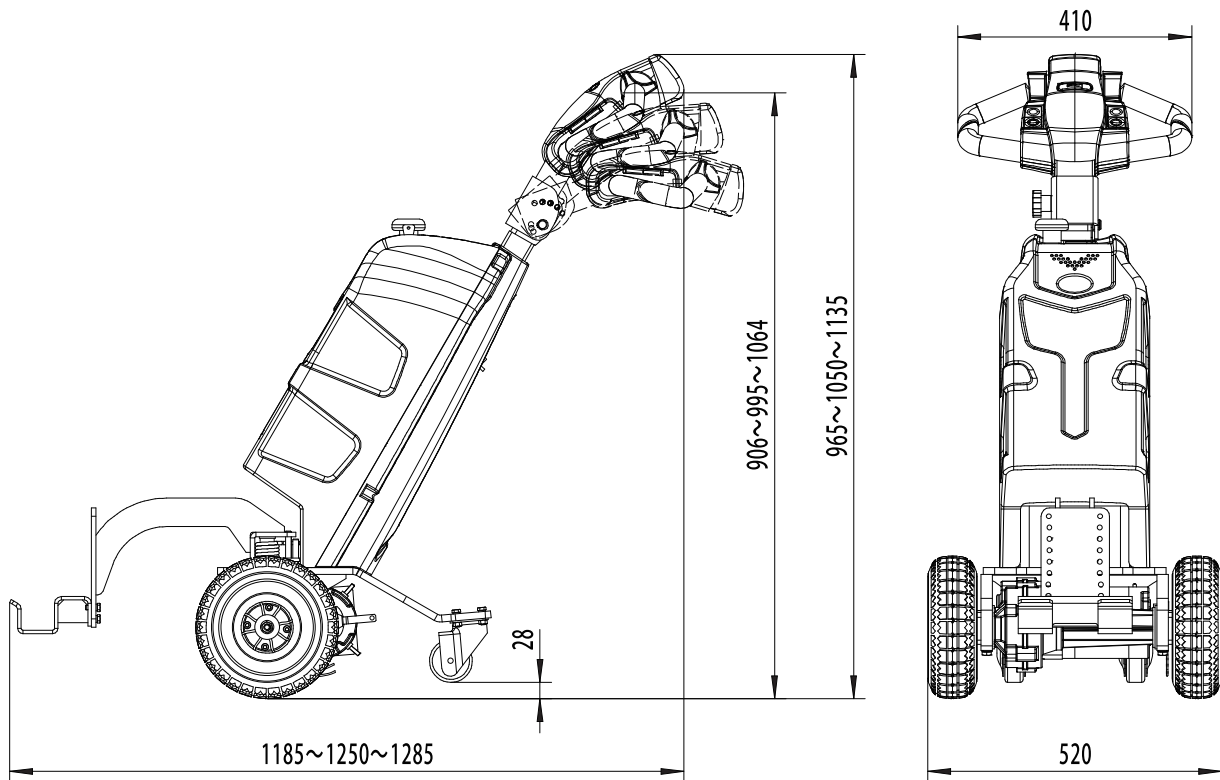

## Option:

No.	Optional items	QDD10
2.3	Drive wheel material	●Rubber
2.5	Front wheel material	●Pneumatic ○ solid
2.7	Battery capacity	●50Ah
2.8	Charger	●24V-8A internal
2.9	Battery indicator	●Without time ○ With time
2.13	Traction pin	●No ○ Yes and not customized
2.16	handle head type	●Hands big handle head

Note: ●Standard ○ Optional - Inconformity